

Line to Ground Voltage Monitoring on Ungrounded and Impedance Grounded Power Systems

December 2010/AT301

by Reza Tajali, P.E.
Square D Power Systems Engineering

Make the most of your energySM

Revision #1 12/10

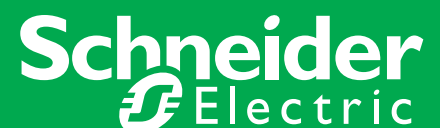

Abstract

Power monitoring devices are sometimes used on ungrounded and impedance grounded systems to record and alarm on line to ground voltages. This recorded line to ground voltage data can be manipulated using a host of data analysis tools to evaluate insulation stress on power system components. However, ungrounded and impedance grounded systems have specific issues that impact proper application of metering equipment. Voltage transformers are especially prone to misapplication. This paper is intended to provide a road map for proper application of power monitoring in these circuits. The subject of grounding is explored to demonstrate the basic issues with ungrounded systems. A discussion of metering principles is provided to identify the limitations for this type of metering. Ample discussion is provided on the subject of controlling ferro-resonance.



Get connected
to power

I. Introduction

Power monitors are generally designed for two basic metering connections. Three element metering is normally used on 3 ϕ 4w feeders where system neutral is available. These systems are solidly grounded. Two element metering is generally applied to any 3 ϕ 3w feeder. A 3 ϕ 3w feeder is one for which system neutral is not available or can not be used. Specifically this includes ungrounded Delta, ungrounded wye and impedance grounded wye systems. See Figure 1.

The special application discussed in this paper utilizes three element metering on an ungrounded or impedance grounded system. This is a variation from the norm in metering electricity. This method of metering is applied to measure line to ground voltages.

II. Metering Accuracy

The principle behind all electricity meters, most popularly known as Blondel theorem, is stated as follows:

“The total power of a general n-phase system is the sum of n powers. These powers are given by n currents which issue from the n terminals, with the n potential differences of these terminals against any arbitrary terminal.”

For a three phase system this principle is shown graphically in Figure 2. The reference point for voltages (V_x) can be any point. In the case of the metering system discussed in this paper, this point is taken to be the earth potential. This point does not have to be the neutral of the system.

With voltages measured line to ground in an ungrounded or impedance grounded system, the individual phase power values (KW, KVAR, KVA) may be meaningless. Some of these individual phase powers may come out positive, some may come out negative. But, per Blondel's theorem, the total 3 phase power will always add up to the correct value. Additionally, if the meter calculates power factor by dividing 3 phase power with 3 phase KVA, the power factor values will be correct. If the meter displays any individual phase power factor values, those values will be meaningless.

There is not one consistent method for calculating the power factor – especially in the presence of current and voltage distortion. Different power monitors use different methods. Individual manufacturer must be consulted.

Disturbance monitoring is an important feature of power monitors which will be affected by the connection method. With the three element connection discussed in this paper, disturbances (sag, swell, transients) are measured with respect to ground. Voltage distortion is also measured with respect to ground. Care must be exercised when interpreting these data.

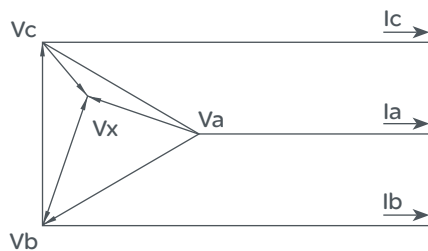

Figure 2: Blondel theorem

III. What to Measure

The following values are of particular interest on ungrounded systems:

- 1.) RMS value of line to ground voltages: A significant increase in voltage unbalance will signify a ground fault condition.
- 2.) Line to ground voltage transients: If the system is ungrounded, be prepared to see a great number of transients on some feeders – especially on an aging power system. These transients may disrupt sensitive electronic equipment and stress the insulation on electrical machinery. Waveform captures from these transients can be used to evaluate possibility of partial (arcing) ground faults and ferro-resonance.



Get connected
to power

IV. Impedance Grounded Systems

Figure 3 depicts the voltage connection used for monitoring line to ground voltages on an impedance grounded systems. By monitoring line to ground voltages it is possible to detect and alarm in case of ground faults.

In addition to individual phase currents, the power monitor will measure and display the vector sum of the phase currents. With the connection under discussion, this vector sum will be equal to the ground current. Some power monitors have the capability to directly measure the ground current. See Figure 4.

Even though the voltage transformers are connected line to ground, it is recommended that the transformers' primary side have a voltage rating at least equal to the system's line to line voltage. This is because a line to ground fault on any phase will impress the line to line voltage on the transformers on the other two phases.

This type of system is not prone to voltage transformer ferro-resonance. Therefore, the metering circuit will not require any burdening resistors (the subject of ferro-resonance will be discussed later in this paper.)

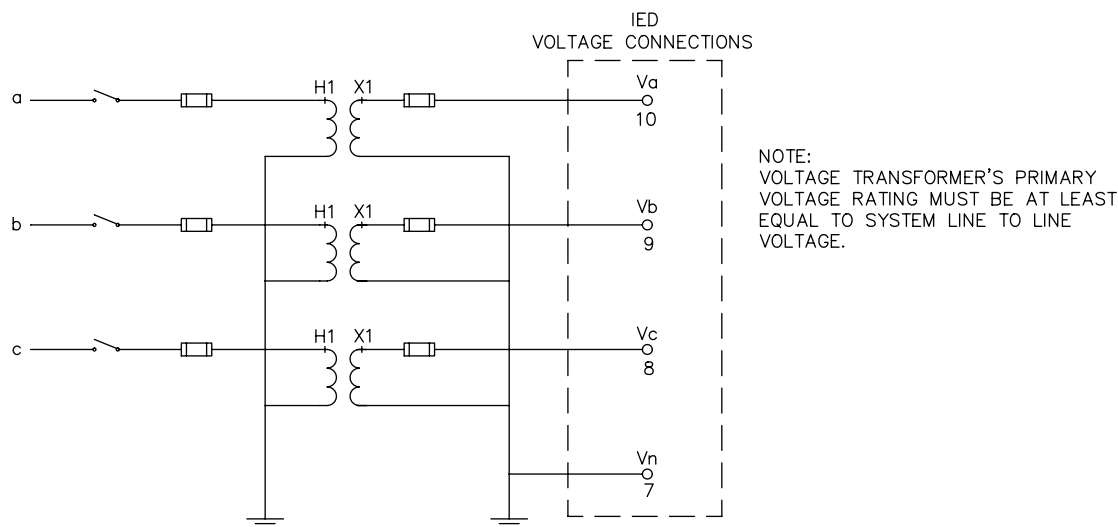
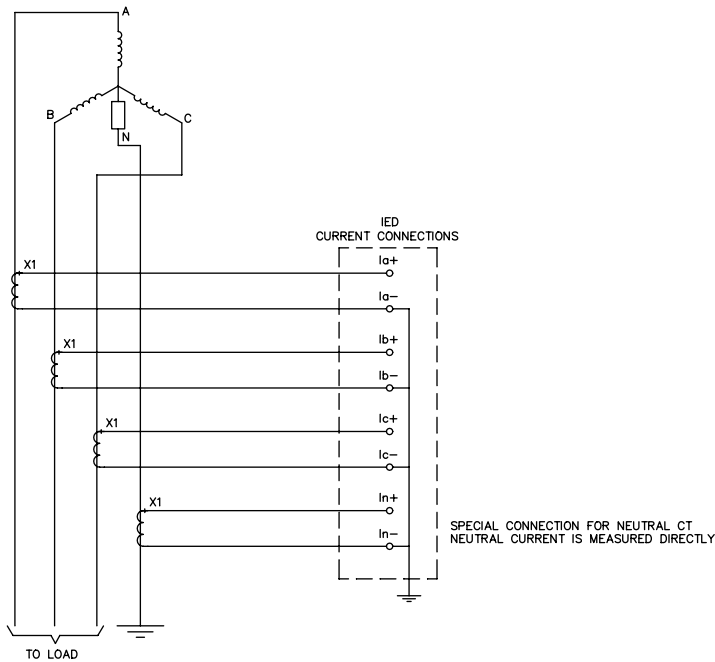

Figure 3: Optional voltage connection for impedance grounded systems.



Get connected
to power



Get connected
to power

Figure 4: Current transformer connections for impedance grounded system

V. Ungrounded Systems

A. Ungrounded Systems' Inherent Instability

Historically, there has been a gradual trend in American practice from ungrounded systems to solidly grounded or impedance grounded systems. Initially, most systems were ungrounded - this was the natural thing to do as the ground connection was not necessary for the actual transfer of power. This method had a strong argument in its favor as insulation failure on one of the phases could be tolerated for some time until the fault could be located and repaired.

A major limitation to the ungrounded system has been the arcing ground fault. By arcing ground is meant a process by which alternate clearing and re-striking of the arc causes recurring high surge voltages. These surge voltages stress the insulation on other parts of the system causing premature equipment failure.

Additionally, in an ungrounded system, the voltages to ground are inherently unstable. To understand these principles a simplified model of the system is drawn (Figure 5).



Get connected to power

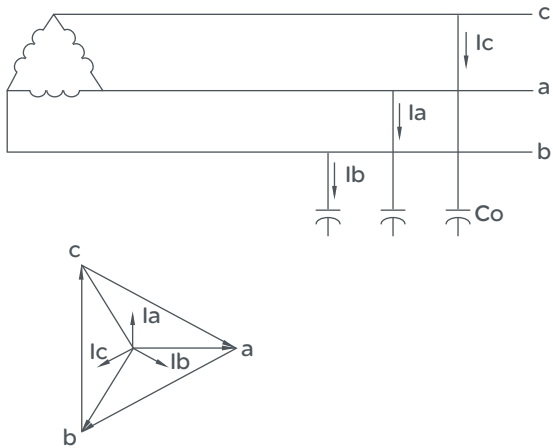

Figure 5 – Simple ungrounded system

The system capacitance to ground is modeled by three shunt capacitors C_{ϕ} . Under ideal conditions, with system impedances balanced, the charging currents from the three capacitors add to zero. So far as voltages are concerned, a virtual neutral point can be envisioned in the delta transformer which will be at ground potential in such an ideal system.

In actual practice the system impedances are not exactly balanced and the virtual neutral point, discussed above, is not at earth potential. Therefore, the individual phase voltages to ground will not be equal.

Figure 6 illustrates the situation encountered in a line to ground fault. During an arcing ground fault the circuit depicted in Figure 6 is opened and re-struck due to the action of the arcing fault. This action creates significant voltage transients.

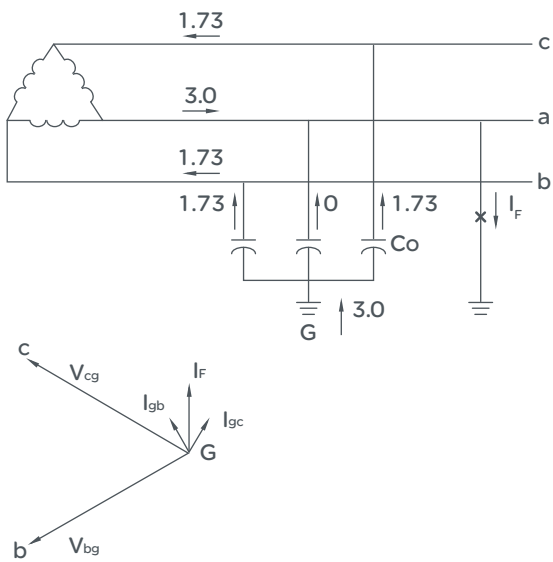

Figure 6 – Ground fault on simple ungrounded system

The solution to these problems of ungrounded systems is to provide system grounding, either directly or through an impedance. In case of a wye connected system the neutral point is directly available and can be used. In case of a delta connected system, the neutral point can be derived through grounding transformers. Figure 7 demonstrates two approaches in using grounding transformers.



Get connected to power

The grounding resistance is sized so that the magnitude of ground current during a line to ground fault would be slightly larger than the system capacitive charging current. This provides the highest value of resistance that is acceptable (hence High Resistance Ground). The grounding resistance can be smaller than this value. But at these lower values the magnitude of ground fault current increases.

Such properly sized grounding resistance will provide damping to voltage transients during arcing ground faults. It can be said that it stabilizes the power distribution system. Essentially, this kind of system has all the advantages of ungrounded systems plus the added benefit of controlling line to ground voltage transients and voltage transformer ferro-resonance (Ferro-resonance will be discussed later in this paper).

Once the magnitude of the ground fault current is established, the transformers in Figure 7 are sized to carry this current. This establishes the thermal rating of the transformers.

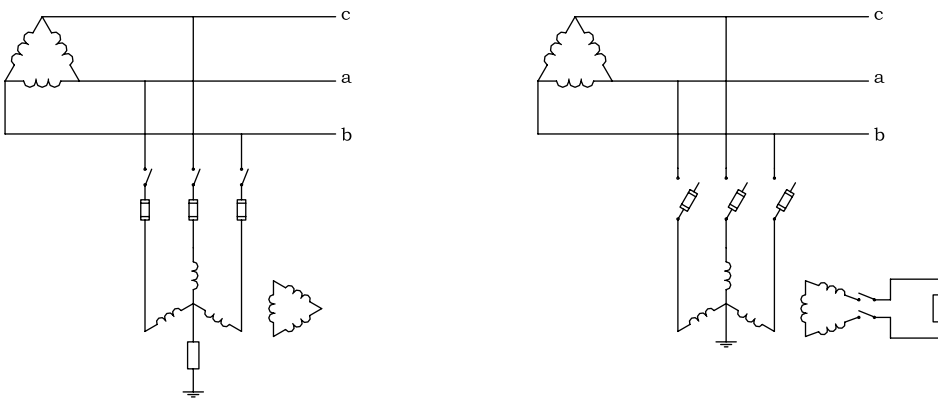

71

Figure 3: Ground Fault on Load Bus #1 Could Shut Down the Entire Data Center

B. Ground Fault Indicating Circuits for Ungrounded Systems

Despite the advantages of grounding through impedance, many installations remain ungrounded. This is primarily because of economic reasons. In these instances, the circuit depicted in Figure 8 has been commonly used. During a phase A to ground fault, the phase A pilot light would burn dimly while phase B and C pilot lights would be brighter than normal. The problem with this system has been that the pilot lights are usually not under continuous supervision. Therefore, relay “CR” is introduced to alarm in case of a ground fault.

This diagram shows a “Resistor” installed in the open delta. This resistor is used to dampen the effect of ferro-resonance. The subject of ferro-resonance will be discussed in the next section.



Get connected to power

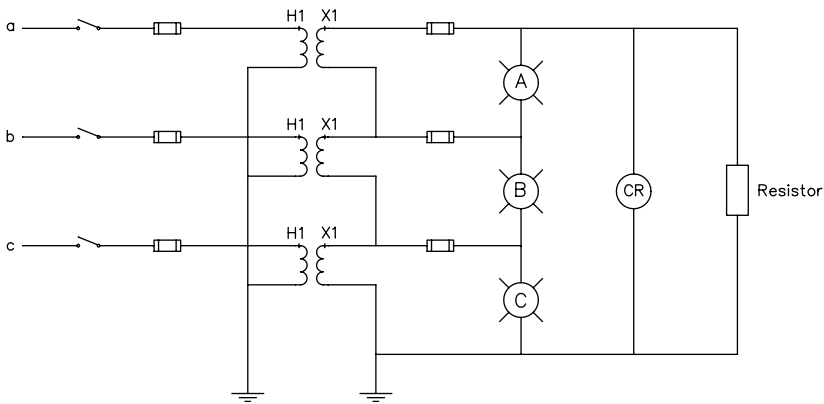

Figure 8 – Ground fault indicating lights

It is of particular interest to compare Figure 7b and Figure 8 above. There is a similarity in transformer connections (both schemes use Y-Δ connections and a resistor.) But the similarity is in schematic only and the two systems differ in thermal withstand and selection of the resistors. The resistor in Figure 7b is sized to allow sufficient current flow to stabilize the power system while the resistor in Figure 8 is significantly larger in ohmic value. This resistor (Figure 8) is installed to dampen the ferro-resonance condition that could be caused by voltage transformers. It does not allow sufficient current flow to stabilize the ungrounded power system.

A better approach to the alarm system depicted in Figure 8 would be to replace the pilot lights with a power monitoring Device and connect the transformers in a wye-wye configuration (Figures 9). In this case three damping resistors are installed –one on each phase. Data on the sizing of the resistors will be provided in the next section.

With a power monitor we have the capability to evaluate the line to ground voltages as well as the line to line voltages. This provides a complete monitoring of the voltage quality.

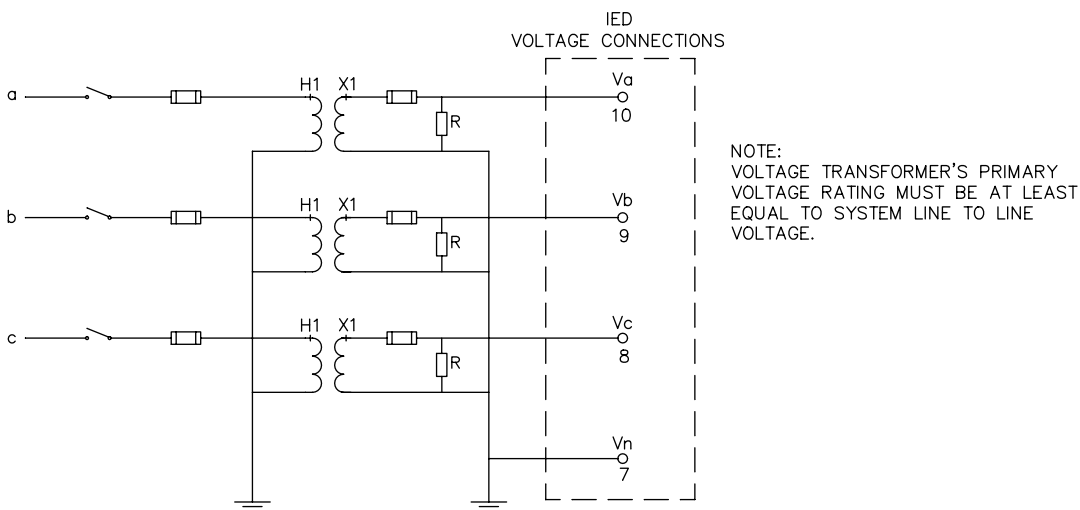

Figure 9 – Voltage transformer connections for ungrounded system

VI. Ferro-Resonance

The following discussion on ferro-resonance is provided with the assumption that voltage transformers are used (existing installations predominantly use voltage transformers). Some newer power monitor designs can accept voltage inputs up to 600 volts without any need for voltage transformers. These units pose as a large resistance when connected to the power system. Where voltage transformers are not used, there is no concern for this type of ferro-resonance. However, care must be exercised when applying these power monitors without voltage transformers. Many of these units do not have the proper rating to be used on ungrounded systems. Consult with the power monitor manufacturer.

In this context, ferro-resonance refers to the circuit created by a variable or saturable inductor and power system's distributed capacitance (Figure 10).

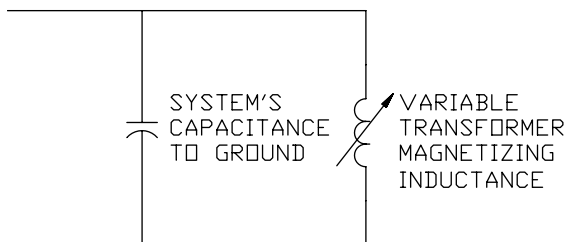

Figure 10 – Ferro-resonance

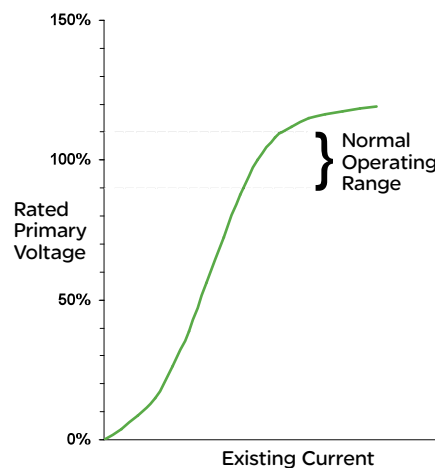

Figure 11 – Transformer magnetizing curve

The magnetizing impedance of transformers is nonlinear as depicted in the transformer's magnetizing curve (Figure 11). Transformer's magnetizing impedance and system's capacitance can cause this special type of resonant condition. In order to excite this circuit the voltage must rise into the saturated region of the transformer's magnetizing curve. Voltage transients caused by switching or arcing ground faults can trigger this condition.

The result of this resonant condition is that high voltages will appear, especially across the open delta of a set of VT's connected per Figure 8. Depending on the size of the system, significant voltages to ground may appear in the power system itself. The resistors in Figures 8 and 9 are introduced to provide damping to the ferro-resonance circuit. It must be noted that there is not a fixed value of "R" that would solve every ferro-resonance problem.

Due to the complex nature of the varying magnetizing reactance, direct analytical solutions were not possible until recent times. Using digital simulation, it is now possible to model the network. But these simulations are rather complex and they are invariably based on some fundamental assumptions about the power system's distributed capacitance and varying inductance. Validity of the results is tempered by the inherent error in these assumptions. Therefore, the results must be proven by actual field measurement.



Get connected
to power

Prior to the advent of digital simulation, however, several empirical formulas were developed based on significant testing and field experience. The results of these tests and the empirical formulas have been published in IEEE papers since 1930's. Of particular interest is the work by H. A. Peterson and the work by Taylor and Carlicek (See the list of References). It must be noted that no conclusive standard has been developed on the sizing of "R". Therefore, there is no "guarantee" of results.



Get connected
to power

It is generally agreed that there is a critical value of "R" below which ferro-resonance is unlikely. However, the two papers mentioned above recommend different methods, arriving at somewhat different results. Readers are encouraged to study the original references for a full description of the methodology and the results.

According to Peterson's findings:

$$R_{\max} = X_m / 3N^2 \quad (1)$$

Where N is the transformer ratio and X_m is the voltage transformer's magnetizing impedance at the rated voltage in ohms. Specifically, the magnetizing impedance is the ratio of the rated RMS primary voltage to the RMS value of magnetizing current at this voltage. It must be noted that the value of X_m is not readily available from manufacturer's catalog. It is much easier to simply take a measurement.

According to Taylor / Karlicek's findings:

$$R_{\max} = 100 L_a / 3N^2 \quad (2)$$

Where N is the transformer ratio and L_a is the saturated or air core inductance of the voltage transformer primary windings in millihenrys. L_a can be easily calculated from the geometry of the windings.

Equation (2) may derive a lower value for "Rmax" compared to equation (1).

The laymen, having to solve the problem day to day, came up with a rather interesting "rule of thumb" as the solution. The value of "R" was selected to provide the maximum allowed burden on the transformer under worst conditions. The worst case burden is placed on the transformer during a line to ground fault. During a line to ground fault the voltage across the transformer will be equal to the system line to line voltage, providing maximum current flow. The value of "R" is selected such that transformer's burden rating is not exceeded. This is the lowest value of "R" that can be used on this transformer.

If this value of "R" would not do the job, it would be necessary to select a transformer with a higher burden rating. The resistor can not be any smaller! It must be noted that this selection for the value of "R" is rather arbitrary in that a larger value may do as good of a job as the minimum value calculated by this method. Additionally, the accuracy of the voltage transformer is severely taxed by being burdened to its limit. If the user can perform some testing of his own, he can determine a more optimum value for "R". The calculations presented above can be used as a sanity check, or a starting point.

In case of Figure 8, the value of the resistor across the open delta will be three times the value calculated by equations 1 and 2.

Sample Calculations:

Three voltage transformers with primary rating of 480 volts (4 to 1 ratio) are to be connected per Figure 9. The transformers have a continuous thermal rating of 500VA, a burden rating of 200VA for 1.2 accuracy class and 75VA for 0.3 accuracy class. The power system is 480V delta, ungrounded. Design the metering circuit components.



Get connected
to power

A. Peterson's Method

Apply, to the primary of the transformer, a voltage as close as possible to the full rated transformer primary voltage and measure the exciting current. A sample transformer was selected. 472 volts RMS was applied and the RMS value of magnetizing current was measured at .03 amperes. The critical value of "R" is calculated as follows:

$$X_m = 472 / .03 = 15733$$

$$R_{\max} = X_m / 3N^2 = 15733 / (3 \times 4^2) = 328\Omega$$

B. Maximum Burden Method

The 1.2 accuracy class is the lowest acceptable for metering. So the maximum burden of 200VA is used for calculations.

The value of "R" will be calculated to produce maximum allowed burden (lowest allowed resistance):

$$R_{\min} = 120^2 / 200 = 72\Omega$$

A standard 75 Ω , 225W resistor can be used. In case of the circuit in Figure 8, the value of the resistance across the open delta will be three times the value calculated above.

A value closer to the thermal rating of this transformer (500VA) could have been used for this calculation. At that level of burden, the accuracy of the transformer would not be suitable for metering. However, at high burden, this set of transformers would still work as a ground fault detection circuit. In actual application, it is possible that the requirements of metering accuracy and ground fault detection come in conflict with one another.

In order to avoid this potential conflict, for ungrounded systems, it is recommended that a separate set of voltage transformers (and a separate power monitor) be installed for ground fault detection. This set of voltage transformers will be dedicated to monitoring and alarming for ground faults. By keeping the metering circuit separate from the ground fault detection circuit, each circuit can be optimized.

C. Voltage Transformer Overcurrent Protection

The customary practice is to size voltage transformer primary fuses to provide short circuit protection and withstand transformer inrush current. Generally, the primary fuses do not provide satisfactory overload protection in case ferro-resonance is encountered. So it is important to remove ferro-resonance by damping the circuit as discussed above.

D. Resistor Installation Considerations

Select a resistor that carries UL listing. Listed devices are evaluated for safety and are generally approved by local jurisdictions.

Also note that resistors generate heat. Contact the switchgear manufacturer for recommendations about resistor installation. Switchboard standard UL891 allows a maximum of 250 watts of this type of resistance heat in each section of the switchboard. Therefore, the resistors may have to be mounted outside of the switchgear enclosure.



Get connected
to power

VII. The Case of Y-Y Connected Power Transformer

Power system transformers are often connected in a wye-wye configuration. These transformers may be ungrounded, grounded or they may be provided with a tertiary delta winding. A number of combinations of grounding arrangements are possible. Under certain conditions, significant voltage to ground distortion will be present on the secondary side of these transformers. The subject is discussed in the Westinghouse Electrical Transmission and Distribution Reference Book (see the references at the end of this paper). This section describes the basic reason why the voltages to ground become distorted and their effect on metered values. This discussion also serves to demonstrate a basic problem in interpretation of data when only line to ground voltages are measured.

The magnetizing current of power transformers is inherently nonlinear. This is because power transformers are normally worked into the saturation region of their magnetic core. This inherent non-linearity of the magnetic B-H curve causes the magnetizing current to be non-linear.

This magnetizing current has a significant third harmonic component. Where this third harmonic magnetizing current is able to flow, the flux in the transformer core and the voltages remain essentially sinusoidal. The problem arises where this third harmonic current can not flow.

Figure 12 shows examples of where the third harmonic magnetizing current can and can not flow.

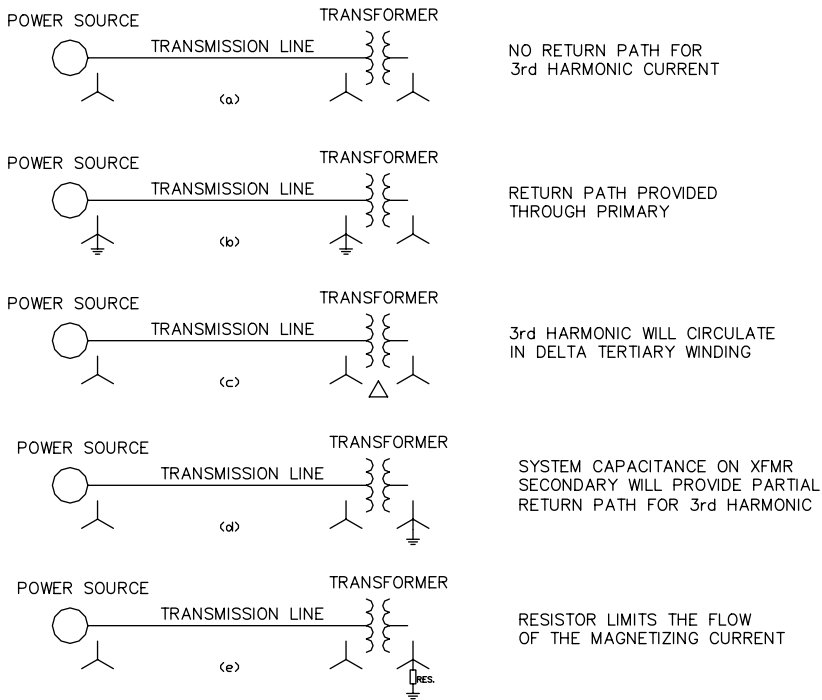

Get connected
to power

Figure 12 – Connections that influence the flow of third harmonic exciting current (per Westinghouse Electrical Transmission and Distribution Reference Book)

Where the third harmonic current can not flow, the voltages to ground will be distorted. These cases normally occur where:

- 1.) The power transformer is wye-wye connected.
- 2.) Either the system generation or the transformer primary is not grounded.
- 3.) The transformer secondary is ungrounded or impedance grounded. Also, in some cases, with grounded secondary.
- 4.) Tertiary delta winding is not provided to circulate the third harmonic magnetizing current.

In these instances, the line to ground voltages will have a peaking third harmonic component as illustrated by the waveform capture in Figure 13. Lines to line voltages, however, are not affected. Figure 15 shows line to line voltages calculated from the line to ground waveforms.



Get connected to power

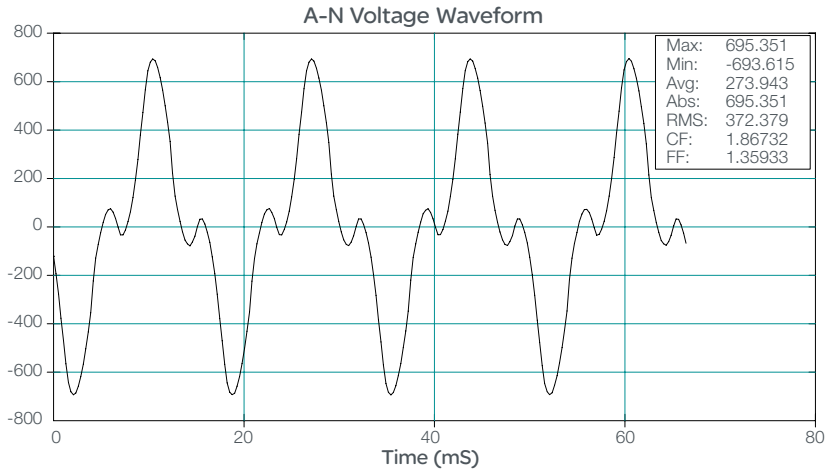

Figure 13 – Line to ground voltage on transformer secondary

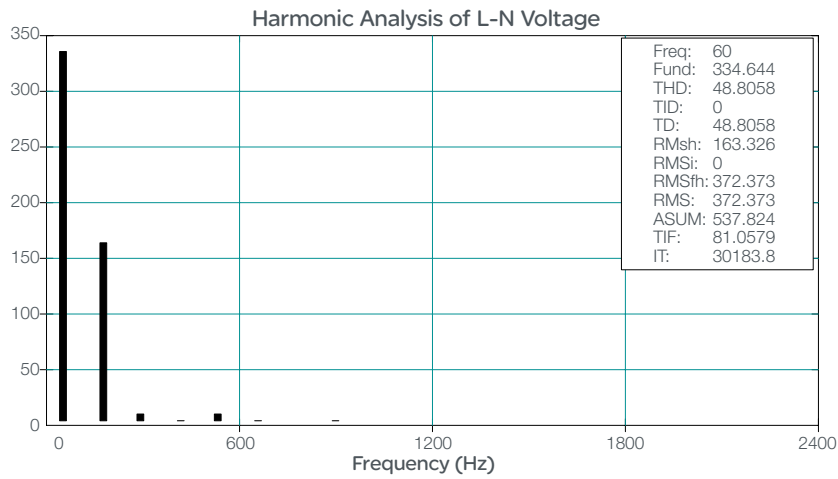

Figure 14 – Harmonic spectrum of line to ground voltage shows significant third harmonic component

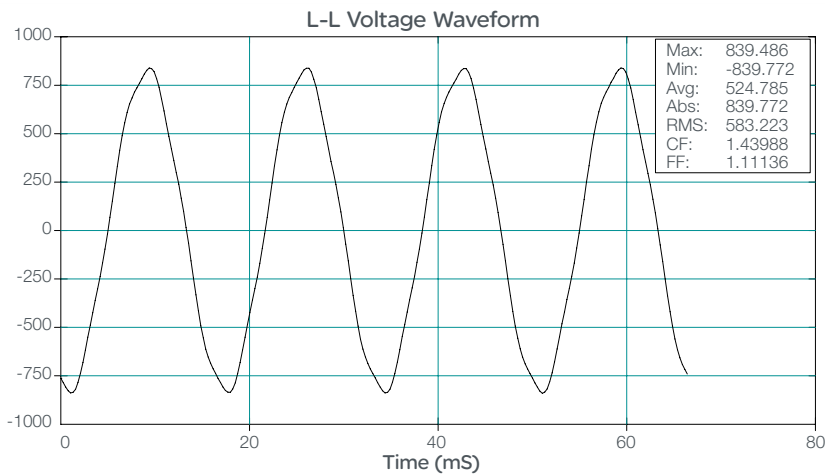

Figure 15 – Line to line voltage calculated from line to ground voltages

When configured for three element metering, power monitors utilize only the line to ground voltage values for calculations. This includes sag/swell detection and waveform capture. Care must be exercised when interpreting these data.

The waveforms captured (line to ground voltage waveform) and the calculated harmonic data should not be directly used to evaluate the quality of the voltage provided by the utility. However, as shown in Figure 15, the third harmonic component of the line to ground voltages will not appear in the line to line voltages. Therefore line to line voltages can be used to evaluate the voltage quality. The line to line waveform must be calculated from the line to ground waveforms. The calculations can be performed by a waveform analysis software.

The above discussion is an extreme example of the problem in interpretation of data. This applies to all line to ground voltage measurements in ungrounded and impedance grounded systems: If you look at the line to ground voltage measurements directly, you will not obtain a usable estimate of voltage quality from the standpoint of distortion and voltage sags (two main indices of power quality).



Get connected
to power

VIII. Conclusions

- 1.) Power monitors can be configured to measure line to ground voltages in ungrounded and impedance grounded systems. Whether a power monitor is connected in this fashion or in the classical 2 element fashion depends on the purpose behind taking measurements. The user must understand the limitations of this connection type to correctly make this choice.
- 2.) The primary function of this type of metering has been ground fault detection. It must be noted that this feature is not a “protection” feature - which is normally left to protective relaying. In this application, power monitors are used for monitoring and alarming purposes. On ungrounded systems, significant line to ground voltage unbalance can signify a ground fault. Arcing grounds and ferro-resonance conditions can be detected using transient capabilities of the power monitor – where the device is provided with this capability.
- 3.) This type of connection will have an impact on the transient recording and sag/swell features of the power monitor. All these values will be referenced to ground. Additionally, the voltage harmonic measurements and waveform capture feature will be referenced to ground. The user must weigh this limitation against the advantages provided by this connection.
- 4.) The basic metering values are calculated correctly. Power monitors have different methods for calculating the power factor (displacement and total). Whether the power factor values will be correctly depicted depends on the power monitor design.
- 5.) Some power monitors are designed for direct connection to circuits up to 600 VRMS. Care must be exercised when applying these devices in a three element configuration to ungrounded systems. Voltage to ground levels may exceed the rating of the power monitor, especially in the presence of ferro-resonance. Manufacturer of the device must be consulted. It may be necessary to use voltage transformers.
- 6.) When applying three element metering with voltage transformers on an impedance grounded system, burdening resistors are not required. It is recommended that the voltage transformers’ primary be rated for system’s line to line voltage.
- 7.) When applying three element metering on an ungrounded system, the voltage transformers may need to be burdened to avoid ferro-resonance. Additionally, voltage transformer primary must be rated for system’s line to line voltage. The selection of the burdening resistor is an art in its own. It may be required to place such burden on the transformer that the transformer accuracy will be severely reduced. Therefore, it is common practice to use separate voltage transformers for ground fault detection and metering circuits. (3 element connection for line to ground monitoring, and 2 element connection for metering).
- 8.) Wye-Wye connected power transformers can be a special problem in the application of three element metering for line to ground voltage detection. Under certain conditions significant peaking third harmonic line to ground voltages can be present on the secondary of the power transformer. Care must be exercised when interpreting the disturbance recording and harmonic measurement values.



Get connected
to power

References

- 1.) Ferro-resonance of Grounded Potential Transformers on Ungrounded Power Systems, R. F. Karlicek & E. R. Taylor, Jr., AIEE Transactions,
- 2.) Transients in Power Systems, Harold A. Peterson, Wiley Press, New York, 1951
- 3.) Electrical Transmission and Distribution Reference Book, Central Station Engineers of Westinghouse Electric Corporation, Westinghouse Electric Corporation, Pittsburgh, 1964
- 4.) Voltage Transformer Ferro-resonance in cogeneration substation, William S. Vilcheck and Michael V. Haddad, IEEE, 1992
- 5.) Criteria for Neutral Stability of Wye-Grounded-Primary Broken-Delta-Secondary Transformer Circuits, H.S. Scott and H.A. Peterson, AIEE Transactions, November 1941
- 6.) Physical Nature of Neutral Instability, A. Boyajian and O.P. McCarty, AIEE, 1930
- 7.) Neutral Inversion of a Single Potential Transformer Connected Line-to-Ground on an Isolated Delta System, Lyle L. Gleason, AIEE, 1951



Get connected
to power



Reza Tajali, a registered electrical engineer in several states, is an engineering manager for Schneider Electric's Square D Power Systems Engineering group in Nashville, Tennessee. He has more than 20 years experience with electrical power distribution and control. Tajali holds two United States patents on switchgear products. He manages a group of engineers who are responsible for power system analysis and reliability assessment on industrial and commercial facilities. That work includes inspection, measurement, analysis and simulation of power systems.

Schneider Electric USA, Inc.

Data Center Solutions
1010 Airpark Center Drive
Nashville, TN 37217
615-844-8300
sedatacenters.com