

Low Voltage Circuit Breaker Guidelines for Data Centers

Reliability requires consulting engineers and end users
to grasp design, maintenance basics

December 2010/AT302

by Reza Tajali, P.E.
Square D Power Systems Engineering

Make the most of your energySM

Revision #1 12/10

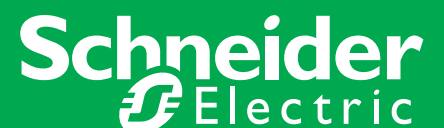

Circuit breaker reliability is the key to data center reliability. As such, a detailed evaluation of the circuit breaker design and functionality at the design stage of the data center is extremely important. Consulting engineers and the end users of data center power systems must understand basic circuit breaker application guidelines in order to ensure the highest levels of reliability.



Get connected to power

Uninterruptible Power Supplies (UPS) provide the critical power for computer equipment in modern data centers. UPS equipment is supplied from commercial power or local generator power, with multiple sources being switched in various arrangements to provide continuous power to that equipment. Such switching requires frequent circuit breaker operation.

Low voltage power circuit breakers are used in modern data centers for the main switching and power transfer operations (Figure 1). Power circuit breakers differ from molded case circuit breakers in that they must comply with rigorous testing criteria established by the American National Standards Institute (ANSI) standard C37. In comparison, molded case circuit breakers are constructed and tested to UL standard 489.

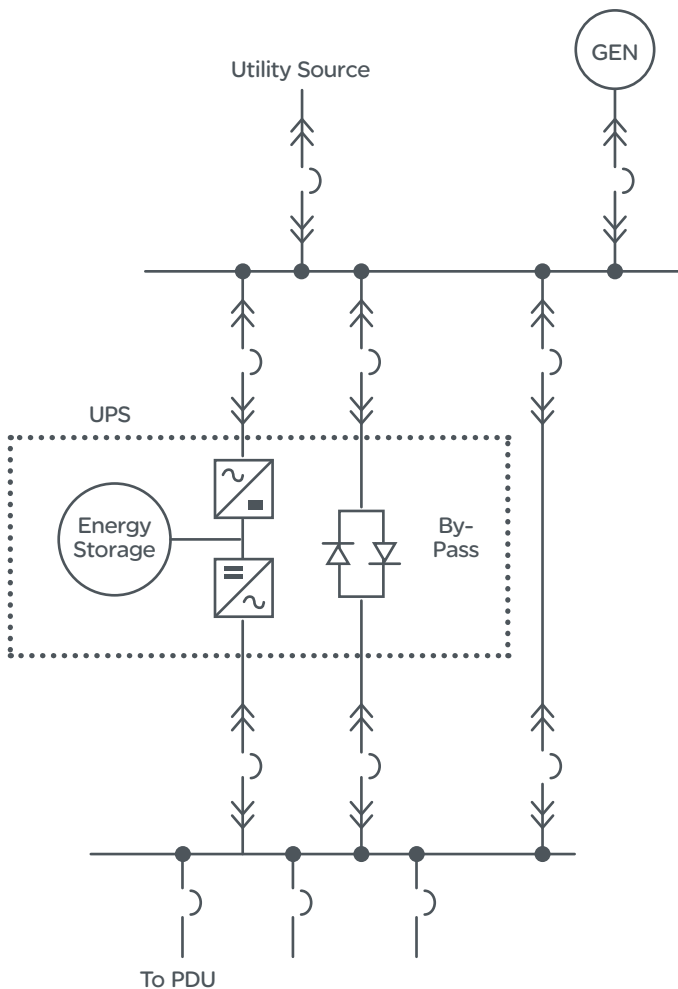

Figure 1: Simple Data Center Power. Circuit Breakers are used Extensively

Boosting Power Systems Reliability

Circuit breakers impact the reliability of data centers in three distinct ways:

- 1.) Design of the circuit breaker must provide reliable continuous operation. Yet, the circuit breaker must act to interrupt the circuit with great speed and efficiency under abnormal conditions.
- 2.) Circuit breakers must be applied in such a way that minimizes human operation errors.
- 3.) The design and application of circuit breakers must optimize the maintenance process. The ideal circuit breaker will measure and communicate its own maintenance needs.



Get connected
to power

Circuit breakers are the most complex power distribution equipment because they must be optimized for two contradictory functions. Much the same as all other power distribution equipment such as transformers and lines, circuit breakers are optimized to carry their normal current continuously.

But circuit breakers must also be able to interrupt currents efficiently – an action that is contradictory to carrying continuous current. Current interruption is a dynamic action where the circuit breaker and the power system work against each other.

For example, when the circuit breaker contacts part, an electric arc is formed. Power system inductance forces the current to flow continuously through the gap created by the open contacts. The circuit breaker must oppose this force in order to interrupt the current. The result is an enormous energy exchange, which brings about heat and air ionization inside the circuit breaker's interruption chamber.

Circuit Breaker Design

Understanding circuit breaker design and construction, therefore, is important for ensuring the proper functioning of power systems. Power apparatus are made of three main components:

- 4.) The current path – usually copper - must provide excellent conductivity.
- 5.) An insulating material is provided, which separates the current path from the supporting structure. This insulation - usually polymeric material - must provide excellent dielectric and thermal characteristics.
- 6.) The supporting structure was originally made from steel. Steel provided the rigidity to withstand normal operation and short circuit forces.

The design of each component has traditionally demanded a different set of requirements. There has been a consistent shift towards combining the insulating medium and the supporting structure into one molded design. When circuit breakers were first introduced, polymeric material could not withstand the pressure created inside the interruption chamber by the interruption process. However, a combination of insulating material and rigid steel was found workable.

In order to make polymeric material suitable for replacing steel, the strength of advanced polymers has been greatly improved. The polymer used to construct modern power circuit breakers is an engineered thermoset composite resin. The electrical power industry has more than 40 years of experience in advancing and refining thermoset materials for use in circuit breakers.

Further, using a single molding reduces the number of parts, which helps improve the overall product quality. The thermoset resin is strong and lightweight, provides better insulation and isolation, and is molded to support and hold the internal parts with no need for adjustment.

UL 489 vs. ANSI C37

Fundamental differences in the design and test philosophies of UL 489 and ANSI C37 bring about construction differences between circuit breakers. UL 489 circuit breakers are not intended to be opened for maintenance. These circuit breakers are designed with no user replaceable parts. But ANSI C37 circuit breakers are designed for access to the contacts and arc chutes so field maintenance can be performed.



Get connected
to power

Another key characteristic of the ANSI C37 rated circuit breakers has been the short time (30 cycle) rating. The circuit breaker is designed to stay latched in the closed position during a short time event while downstream circuit breakers clear the fault. Passing the short time test requires a more robust circuit breaker – both thermally and mechanically.

But many manufacturers of molded case circuit breakers have also been designing and testing their UL 489 rated circuit breaker for short time withstand. Therefore, in today's market, the main difference between the UL and ANSI rated circuit breakers continues to be maintainability.

Traditionally for applications where frequent switching is required, such as power generating stations, ANSI C37 circuit breakers have been used. Those in charge of operating these systems would like to open the circuit breaker and inspect the contacts for wear and functionality. Much the same as generating stations, data center application subjects the circuit breakers to frequent operation. Therefore, ANSI C37 circuit breakers are the circuit breaker of choice.

Advent of Smart Switchgear

Drawout circuit breakers are universally used on critical power switching circuits. The drawout feature significantly reduces the downtime in case a circuit breaker must be removed from service, either for maintenance or because of a malfunction. But the drawout feature can also be the cause of confusion where communicating trip units are used.

Communicating trip units are a common feature of modern circuit breakers. These trip units communicate significant information about the circuit breaker and about the electrical circuit. In order to network circuit breakers together, each circuit breaker must be provided with a unique identity or "address". Modern circuit breakers communicate the circuit's current and a number of other metering parameters (Figure 2).

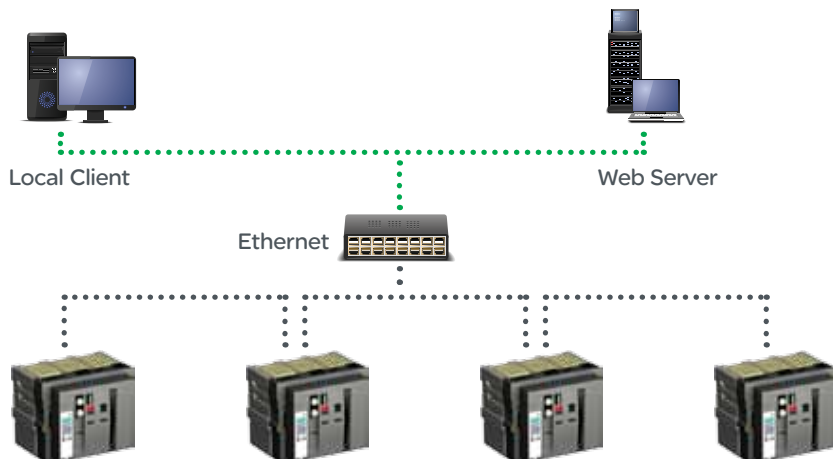

Figure 2: Circuit Breaker Communication Network

As the circuit identity (address) is embedded in the circuit breaker trip unit, we encounter a problem with drawout construction. Assuming that cell 1A feeds a chiller and cell 1D feeds an UPS, when we move the circuit breaker in cell 1A to cell 1D, the circuit breaker is now placed on the UPS circuit. However, the address inside the trip unit still points to the chiller. We will have information pertaining to the UPS circuit being communicated as the chiller circuit (Figure 3).



Get connected
to power



Figure 3: Trip unit communication and drawout circuit breakers

Circuit breaker manufacturers are resolving this problem by developing a Cradle Communication Module. The address is assigned to the switchgear cell. Each time a circuit breaker is installed in the cell, it learns its new address (or identity) from the cell. This innovation has enabled the production of a family of “smart” switchgear.

Maintaining Dependability

Dependability can be engineered and built into equipment, but effective maintenance is required to keep it dependable. Experience shows that equipment lasts longer and performs better when covered by an electrical preventive maintenance program. In the case of modern data centers, the investment in maintenance is small compared to the cost of production losses associated with an unexpected equipment shutdown.

Manufacturers' service manuals typically have a recommended frequency of inspection. The frequency given is based on standard or usual operating conditions and environments. It is impossible for the manufacturer to list all combinations of environmental and operating conditions.

Typically, inside of a power circuit breaker, the main contacts are the components needing inspection and repair. Each time an interruption takes place, a small amount of the surface material of electrical contacts are ionized. Metallurgical science has made major advances in producing advanced metals for contact material. Yet contact wear continues to be a concern for maintenance personnel.

With the significant advancements we have made in using microprocessor technology, one may wonder if it is possible to manufacture a circuit breaker that communicates its contact maintenance needs. Based on significant testing, a new algorithm computes a "contact wear factor" on the basis of the magnitude of the current being interrupted. The cumulative contact wear can be estimated on the basis of the number of current interruptions and the magnitude and duration of each interruption.

One major circuit breaker manufacturer provides this algorithm with their "communicating" trip units. Therefore, maintenance personnel are provided with a "real time" tool to estimate the condition of the circuit breaker contacts.

To help optimize the reliability of data center power systems, consulting engineers and end users should seek out circuit breakers with the following minimum specifications:

- 1.) Circuit breaker cases shall be constructed of molded thermoset resin material for durability and ease of maintenance.
- 2.) Circuit breakers shall be of drawout construction and designed to meet ANSI C37 standard requirements.
- 3.) Circuit breakers with communicating trip units shall obtain their network address from the drawout cell. When a circuit breaker is moved from one cell to another, the circuit breaker must recognize and assume the identity of the new circuit.
- 4.) Circuit breaker trip units shall provide an estimate of contact wear based on the number and severity of current interruptions. Contact wear information shall be available through communications for remote indication.

Understanding and heeding these basic guidelines will improve the reliability of circuit breakers in data centers and in so doing, help engineers provide a better system.



Get connected
to power



Reza Tajali, a registered electrical engineer in several states, is an engineering manager for Schneider Electric's Square D Power Systems Engineering group in Nashville, Tennessee. He has more than 20 years experience with electrical power distribution and control. Tajali holds two United States patents on switchgear products. He manages a group of engineers who are responsible for power system analysis and reliability assessment on industrial and commercial facilities. That work includes inspection, measurement, analysis and simulation of power systems.

Schneider Electric USA, Inc.

Data Center Solutions
1010 Airpark Center Drive
Nashville, TN 37217
615-844-8300
sedatacenters.com